

USER MANUAL



The RAFALE and RAFALE + are EXPRESS products.

GENERAL PRECAUTIONS FOR USE

**READ THIS MANUAL CAREFULLY IN ITS ENTIRETY
AND RETAIN IT IN A SAFE PLACE FOR FUTURE REFERENCE.**

RAFALE and RAFALE + equipment are intended only for professional applications and must only be used by users who are trained in its use.

- **Never** point the burner at anyone (burns can result from contact with the flame or hot air), or towards the gas cylinder or hose, or onto combustible materials (this can cause fires or could cause toxic fumes to be released).
- **Always** close the gas cylinder valve when not in use for an extended period.
- **Never** use this equipment for continuous heating on a fixed station.
- **Never make any modifications to the equipment. Always** contact your EXPRESS distributor for any maintenance or replacement of parts.

For safety reasons all repairs must be undertaken by the manufacturer and distributors. Failure to observe this clause will result in the guarantee being null and void.

It is essential that you read this manual before use.

1/ GAS TO BE USED

The RAFALE and RAFALE + are intended for use with commercial propane **in the gas phase** under pressure: see table of technical specifications. **Never lay the gas cylinder flat.** It should preferably be placed in a special EXPRESS trolley Item. 666. **Never attempt to heat the cylinder** with the RAFALE or with another flame. If problems are encountered in terms of flow-rates, of low pressures or frosting, then use the EXPRESS cylinder coupler Item. 18970 or a cylinder of larger capacity. You should contact EXPRESS in the event of any other malfunctions.

2/ VENTILATION REQUIREMENTS

All RAFALE equipment, like any equipment which uses gas, consumes air and discharges combustion products which contain carbon dioxide, carbon monoxide and water vapour.

Inhalation of carbon monoxide is dangerous and may be lethal at higher concentrations. **It is therefore essential** to ensure that adequate ventilation of workstations is provided when not working in the open air.

A commonly accepted value is 2 m³ of air per kW per hour for continuous use.

3/ PROPANE GAS CYLINDERS AND PRECAUTIONS DURING CONNECTION

The use of propane cylinders is allowed in industrial locations.

Cylinders other than those cylinders connected to the equipment must be stored outdoors or in areas assigned for this purpose (protected from heat and provided with low-level ventilation). Propane gas is heavier than air and cylinders must therefore be kept away from cellars, drains, manholes etc.

4/ CONNECTING THE EQUIPMENT.

The use of the original hose and the original regulator is compulsory with this equipment. To be fitted to a cylinder of sufficient capacity (13 kg cylinders are recommended).



Versions of devices are available for cylinders from other countries: please contact us. Small capacity cylinders (5 kg) do not provide sufficient flow-rates for normal use.

Open the gas cylinder valve. Set the regulator by depressing the button for a few seconds. Check for leaks at connectors (valve/cylinder, inlet to gun) using detergent solution. **ATTENTION:** never use a flame for detecting leaks.

REGULATOR

Characteristics:

Gas: commercial propane.

Maximum inlet pressure: 16 bar Nominal outlet pressure: 1.5 bar to 3.5 bar.

Nominal flow: 6 to 10 kg/hr.

Inlet connection: left-handed cylinder nut NF 21.7 x 1.814. Export : contact us.

Outlet connection: male thread G 3/8 ISO 228.

Safety device: by means of manual reset excess-flow valve.

Operation:

The regulator controls the downstream pressure at a nominal value indicated on the underside of the equipment, irrespective of the pressure upstream of the expansion valve.

Installation:

Check that the inlet connector rubber seal is correctly in place before connecting the regulator to the cylinder. Since leak-tightness is achieved by means of a flat elastomer seal, the regulator inlet nut must not be over-tightened (10 to 20 N.m). Ensure correct gas flow direction, indicated by an arrow beneath the regulator. Connect the hose to the regulator by means of the 3/8G connector, fully tighten (16 N.m) using two open-ended spanners

Do not use a flame to detect gas leaks in the installation: use a product that generates foam.

Excess-flow safety device

The regulator is equipped with an excess-flow safety valve.

In the event of the connection hose splitting or tearing, the safety valve is triggered and restricts the passage of gas.

In the event of the safety device being triggered, all connected equipment must be turned off and the installation inspected. The hose must not be re-connected until after the installation has been checked.

Before using depress the "Push to reset" (R) button for a few seconds.

Servicing

No servicing is required. It is recommended that the equipment be replaced after 10 years of normal operation.

5/ START-UP

Hold the equipment by the handle, taking care to point the burner towards a non-hazardous area. Open the gas cylinder. Depress the regulator reset button for a few seconds. Press the trigger slightly to initiate the supply of gas (listen for the characteristic sound), then fully depress the trigger to achieve ignition. Adjust the regulator to obtain a flame of the appropriate length and power (a good value is of the order of 2 bar). During this operation, keep the trigger engaged. Release the trigger to stop the equipment.

For optimum ignition operation, the spark should be produced about a half-second to one second after the gas is opened. A suitable rhythm should be used to achieve this.

**1 > GAS second
CLICK
2 > 1**

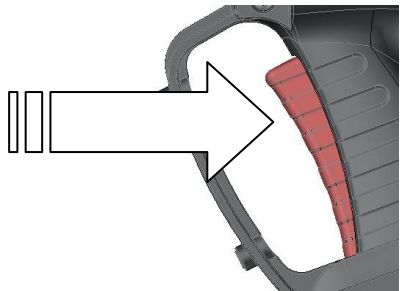

Rotation of the nozzle



- **Disconnect the equipment.**
- Slightly unscrew the knurled screw which holds the burner.
- **Align the nozzle at the desired angle**, re-tighten the screw.

6/ INCIDENTS DURING OPERATION

Always check that you are actually using gas-phase propane and not propane in the liquid phase.

PROBLEMS	CAUSES	REMEDIES
The RAFALE does not ignite. The sound of gas cannot be heard when the trigger is fully depressed.	The cylinder valve is not open.	Open the valve by turning it in the anti-clockwise direction.
	The cylinder is empty.	Replace it with a full cylinder.
	The regulator gauge safety device is in the closed position.	Depress the regulator gauge operating button.
	The gas cylinder temperature is too low (frosting).	Use another cylinder or a larger cylinder. Use the EXPRESS coupler Item. 18970 to connect 2 cylinders.
	The gas cylinder valve flow limiter has been triggered (France)	Close the cylinder valve and open it slowly.
The sound of the gas can be heard when the trigger is fully depressed.	Disconnect the equipment and check that a good spark is produced in the centre of the burner. There is no spark produced.	Check the terminal connection inside the venturi.
	There is no spark produced.	Check the piezo ignition unit.

7/ MAINTENANCE

Always ensure that the equipment is protected against impact and protect the hose from extreme stress (flames, trolley or vehicle wheels etc.).

Change the hose as soon as it starts to deteriorate or after three years use (see technical data sheet for conditions for replacement). The date shown on the hose relates to its date of manufacture.

Clean the exterior of the equipment with a damp cloth in order to keep it clean. After removing the hose (quick connector) blow through both sides of the grille as well as the venturi (at the gun inlet) to

expel all foreign matter. Clean the venturi with a damp cloth introduced through the rear of the equipment.

Removing and refitting the burner

- **Purge the hose, disconnect the equipment.**

- Fully unscrew the knurled screw holding the burner; **withdraw the burner.**

8/ TECHNICAL SPECIFICATIONS

Equipment type	RAFALE	RAFALE +
Energy source	Propane / I3P	Propane / I3P
Qn (at 50.7 psi) (kW)	136485 BTU	221789 BTU
Operating pressure (bar)	21.7 to 50.7 psi	21.7 to 50.7 psi
Adjustable power (from 21.7 psi to 50.7 psi) (kW)	From 81891 to 150134 BTU	From 126249 to 225201 BTU
Flow rate (kg/hr)	From 3.74 to 7.05 lb/h	From 5.73 to 10.58 lb/h
Air consumption (m ³ /hr)	From 36.62 cu yd/ph to 58.85 cu yd/ph (approx)	From 62.78 cu yd/ph to 94.17 cu yd/ph (approx)
Weight (kg)	2.64 lb	2.64 lb
Safety device	"Dead man's handle" with protection	"Dead man's handle" with protection
Excess flow	Excess flow safety device on regulator gauge	Excess flow safety device on regulator gauge
Suitable accessories	Thermal protection "Air" clip	Thermal protection (original) "Air" clip
Noise level (dBA)	82-83	85-88
Certificate No. CE 1312	No.1312BR4450	No.1312BR4450

9/ ACCESSORIES

FITTING THE DEFLECTOR – Item. 35088

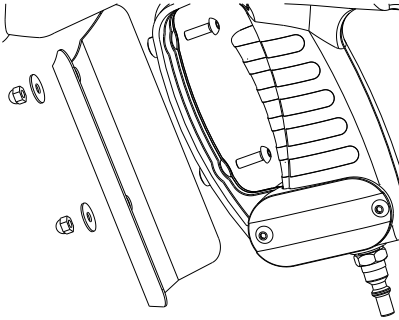

- To prevent too much heat being transferred towards the operator's hand.
- Using the hex spanner supplied with the equipment, fit the deflector as indicated above.

FITTING THE AIR CLIP – Item .35198

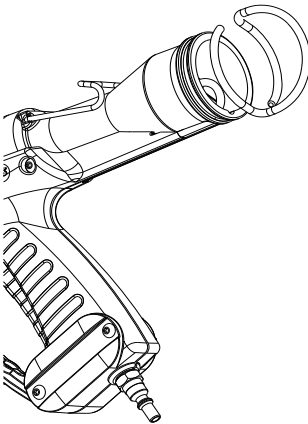



- Prevents working clothes from obstructing the venturi during heat-shrink operations.
- Withdraw the protective O-ring at the rear of the equipment and clip the air clip in this location.

FITTING THE EXPORT CONNECTORS: Pack Item. 35250

These connectors are fitted between the supplied regulator and commercial propane cylinders from foreign sources.

1 - CONNECTOR PACK

R1	Eingang: Ø21.8x1.814 G (Anschluss « KOMBI »)	Deutschland	
	Ausgang: Ø21.7x1.814 G (französischer Anschluss)		
R2	Entrata: Femina Ø20.7x1.814 G	Italia	
	Uscita: Maschio Ø21.7x1.814 prof 60°		
R3	Inner male POL	U.K.	
	Outer: male diam. 21.7x1.814 depth 60°		

2 – ASSEMBLY

If appropriate check that the seals (1) are in place and in good condition. Screw the connector onto the cylinder (tighten using a spanner) then screw the regulator onto the connector. Check that the nuts between the various components are properly tightened. Then follow the start-up instructions.

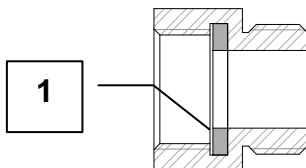

10/ APPLICATION

Heat-shrinking covers around pallets

Heat-shrink covers have much better mechanical properties than those of stretch-wrap. They allow much heavier and larger loads to be secured and provide much better protection against theft. Always operate in a suitable area which is ventilated and free of combustible materials. Protect your hands using appropriate gloves.

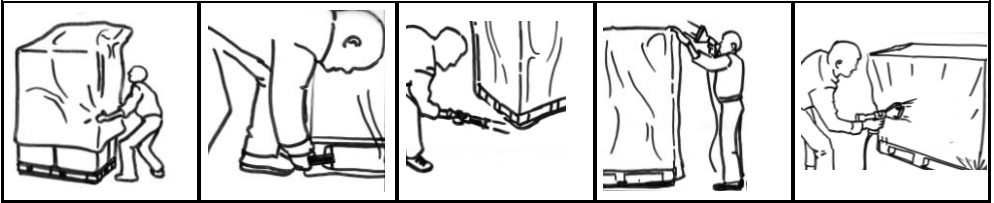

The four corners of the pallet to be shrink-wrapped must be free, and therefore pallets must be raised using another pallet, or better still, a robust support.

A heat-shrinkable film cover can then be slipped on, taking care to avoid tearing it or making holes.

Option: Spot-fix the film to the pallet using staples

Spot-fixing of the top folds (the triangles that remain after the film is folded). Fully heat the area and when the film starts to melt, weld it together by patting it with a glove.

Heat-shrinking of the bottom "belt" of the pallet. This is an essential operation for ensuring that a successful result is obtained. If this operation is omitted then the film will rise up during the main shrink-wrap operation.

Heat-shrinking side faces: work using large movements, starting from the bottom and working towards the top on diagonally opposite faces until a tight surface is obtained. Finish with a light passage on top of the pallet.

Allow to cool: the cover will attain maximum solidity once it is cool.

OTHER APPLICATIONS

Packaging using heat-shrink film has many applications: protection of machinery or mechanical sub-assemblies, transportation of large-volume or heavy products (cycles, mopeds, motorcycles), 'cocooning' of boats for over-wintering, enhancing the rigidity of scaffolding, glazing etc.)

These applications often do not allow a standard cover to be used and film is used to create made-to-measure covers.

If the objects have an irregular shape, fabricate a cube-shaped cover using flat film, allowing an additional area of 35 to 45 cm for self-welding.

Heat the film using repeated movements of the RAFALE whilst simultaneously applying the two layers one over the other with a spatula-type tool in order to join them together, or use an appropriate glove.

When cool, carry out heat-shrinking whilst keeping the equipment at a distance of 25 or 35 cm whilst following the previous instructions.

Please feel free to contact your heat-shrink products distributor at any time for advice on film thicknesses, types and handling.

Other possible applications: weed destruction, heating in the event of frost, disinfection, floor-marking and sealing. Please contact us for further information.

WARRANTY FORM / RAFALE Heat-shrink gun

To be returned to us at the following address:

Retailer's Stamp

GUILBERT EXPRESSWarranty Department (*service garantie*)

F - 33, avenue du Maréchal de Lattre de Tassigny

94127 Fontenay sous Bois CEDEX - FRANCE

USER

Name*		Telephone*:	
Organisation*			
Full address*			
Fax:		Email:	
Distributor*:			
Date of purchase:		Serial No.*:	
Equipment used for:			

*Mandatory information

**GUARANTEE**

- Express provides a full guarantee against all manufacturing defects for all equipment that has not undergone dismantling or any modifications and which is used in accordance with the instructions. This guarantee is expressed through the replacement of defective parts.
- Express provides a guarantee that your equipment will operate correctly for the first two years of use following purchase, on condition that the operating method specified in the instructions has been followed and on condition that your equipment has not been subjected to any impacts (deformation of the body, of the protection wires or of the burner, no damage to threads etc.). This guarantee does not include consumables such as the hose, the automatic igniter and the ignition wire.
- Express will guarantee exchange for a reconditioned item of equipment (in the event of a manufacturing fault or during the first two years following the purchase of the equipment).

The guarantee is only valid on condition that you have returned the duly completed guarantee form. GUILBERT EXPRESS will accept no responsibility for accidents caused to individuals or property due to incorrect use or due to use not provided for in the instructions.

The EXPRESS organisation will accept no responsibility for accidents caused to individuals or property due to incorrect use or due to use not specifically provided for in the instructions. In the event of any dispute, the courts of Paris, France, are deemed to be the sole competent courts. No other jurisdiction locations will be accepted.

The use or resale of RAFALE equipment implies total acceptance of the above conditions.

GUILBERT EXPRESS

33, avenue du Maréchal de Lattre de Tassigny

F - 94127 Fontenay sous Bois CEDEX - FRANCE

www.express.fr/ / [info@express.fr/](mailto:info@express.fr)